

REMOTE TELLER SYSTEM

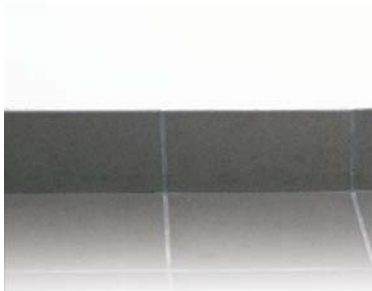

- ▶ Full customer service is provided.
- ▶ Audio and video communication between customer and teller.
- ▶ Physical connection by pneumatic tube system.
- ▶ Remote location of tellers provides increased security.
- ▶ Extended business hours are possible at lower operating costs.
- ▶ Enhancement to marketing by video messaging system that streams commercials.



Client station



Teller station with audio/video connection

*personal, face-to-face
service between client
and teller*

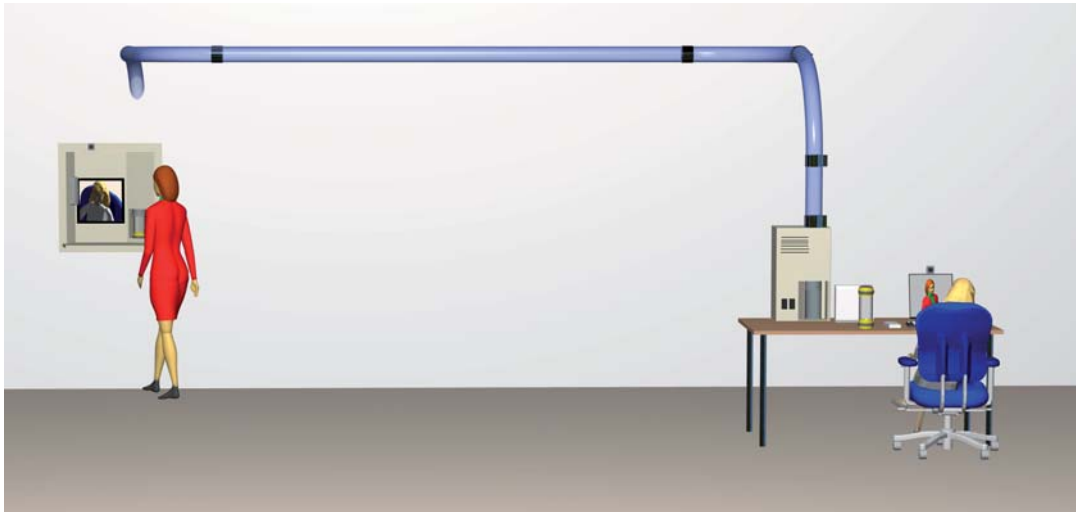

Remote Teller Systems (RTS) are an effective way to offer personal, face-to-face service enhancing security and safety as well as convenience for both: clients and tellers.

The system comprises of one or several client stations in the lobby area connected with the cash desk area via a pneumatic tube systems line. A high-quality video and audio system establishes audio-visual contact between the client and the teller, the pneumatic tube system transports documents, money, account statements, etc., thus facilitating fast, but still individual service.

Promotionally effective advertising and information videos can be streamed in order to shorten the waiting time at the client station.

TECHNICAL FEATURES

- ▶ robust, high end audio-video equipment and state of the art pneumatic tube system.
- ▶ wall-recessed or flash mounting installation and flexible mounting height
- ▶ safe, customer-friendly handling
- ▶ silent operation
- ▶ streaming of promotion videos and commercials enabled by a integrated DVD system
- ▶ tube diameter: 110mm

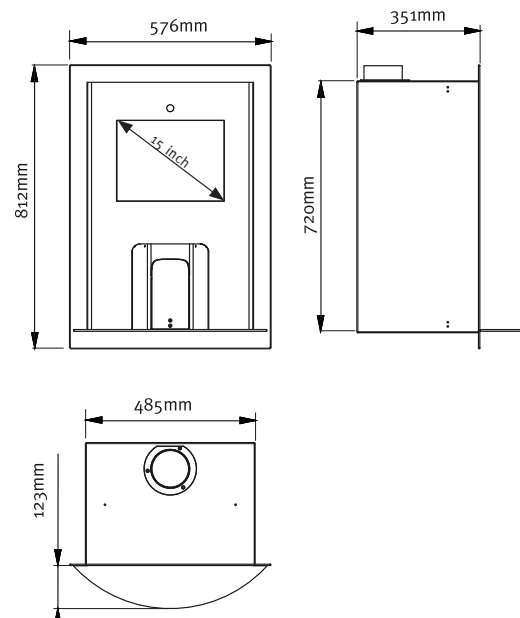

Ing. Sumetzberger GMBH

A-1110 Vienna, Austria, Leberstr. 108, Tel.++43/1/740 35 0, Fax ++43 1 740 35 300
E-mail:pt.sales@sumetzberger.at, Website: www.sumetzberger.com

... plus more than 45 dealerships worldwide.

Sumetzberger